

Sliding Gate Operator User's Manual

PY600AC

1. Products introduction

Please read the instructions carefully before proceeding.

MCU is supplied to control the gate operator.

Keypad / single button interface.

Photo beam safety beam interface.

User can select Auto-close function.

Manual key release design for emergency purposes.

2. Important safety information

Carefully read and follow all safety precautions and warning before attempting to install and use this automatic gate operator.

Make sure the Power supply(AC220V or AC110V) of the gate operator is suitable for the power supply in your area.

3. Main technical parameters

Type	PY600AC	PY600ACU
Power supply	220V, 50Hz	110V, 60Hz
Motor speed	55rpm	66rpm
Rated output power of motor	200W	
Remote control operating distance	30m (Frequency:433.92mHz)	
Remote control mode	Single button	
Output shaft height	58.5mm	
Max. gate weight	600Kg	
Output torque	16N · m	
Limit switch	Spring limit switch	

PY600AC SLIDING GATE OPERATOR

Noise	≤58dB	
Duty cycle	S2, 15 minutes	
<i>extra remote control</i>	20	
Environmental temperature	-20°C~+50°C	
Gate Move speed	13m/min	15m/min

4. Mechanical Installation

The PY600AC will handle gate weighting up to 600 kg and up to 8m/12m if the proper installation procedures have been followed. The PY600AC gate operator operates by forcing a drive rack by a drive gear. The entire configuration is shown in the diagram below. The gate operator must be installed on the inside of the gate.

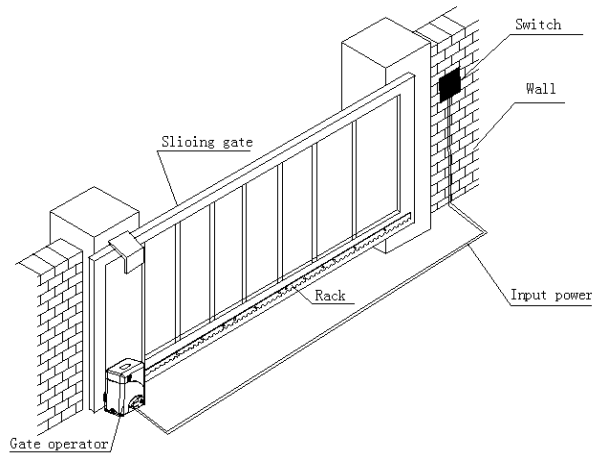

Fig.1

Gate preparation

Be sure the gate is properly installed and slides smoothly before installing the PY600AC sliding gate operator. The gate must be plumb, level, and move freely.

Conduit

PY600AC SLIDING GATE OPERATOR

In order to protect the cable, use PVC conduit for low voltage power cable and control wires. Conduit must be preset into the concrete when it is poured. Wires within the conduit shall be located or protected so that no damage can result from contact with any rough or sharp part.

Concrete pad

The base unit of the gate operator requires a concrete pad in order to maintain proper stability. The concrete pad should be approximately 450mm x 300mm x 200mm deep in order to provide for adequate weight and structure to insure proper stable installation.

Anchors (see Fig.2)

You can use anchor bolts, anchors, washers and nuts. These anchors must be set into the concrete when it is poured or you can use wedge anchors to fasten the operator.

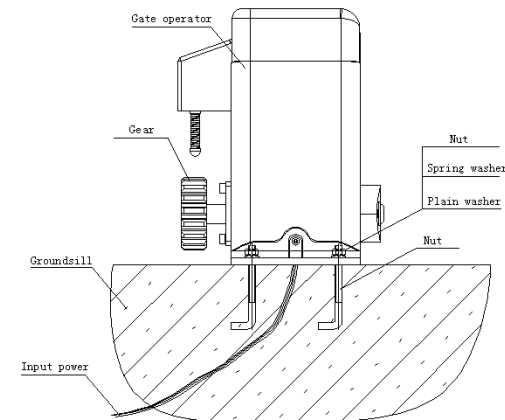

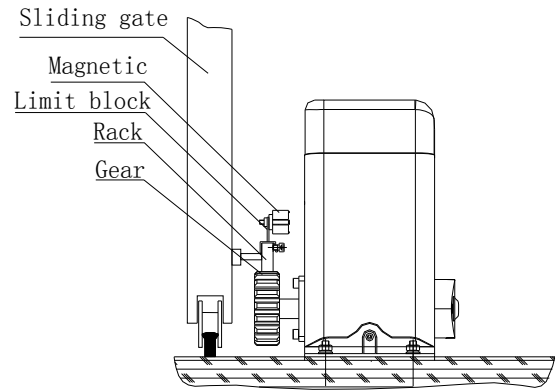

Fig.2

Operator base (see Fig.3)

After the concrete has hardened, mount the gate operator base to the concrete pad. Verify that the base is properly leveled.

Using bolts and washers mount the gate operator to the base and insert the cover. Check the operator and make sure it is lined up with the gate.



Fig.3

Installation of Rack

- Fix the three nuts (in the same package with rack) on the rack element.
- Lay the first piece of rack on the gear and weld the first nut on the gate.
- Move the gate manually, checking if the rack is resting on the gear, and weld the second and third nut.
- Bring another rack element near to the previous one. Move the gate manually and weld the three nuts as the first rack, thus proceeding until the gate is fully covered.
- When the rack has been installed, to ensure it meshes correctly with the gear.
- The space between rack and gear is about 0.5mm.

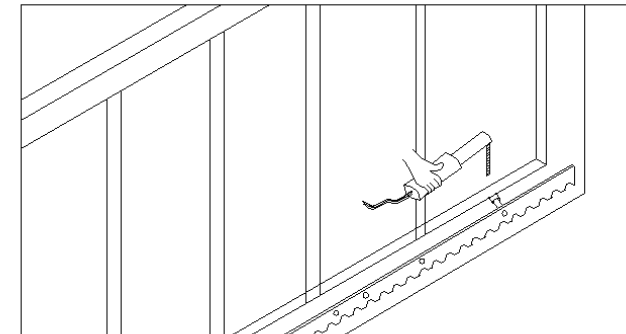

Fig.4

5. Adjustment

Spring limit switch

- To ensure safety, it is recommended to install limit switches at both ends of the gate to prevent the gate from sliding out of the rails. The rails must be installed horizontally.
- Install the limit block as shown in Fig.5 and Fig.6. The spring limit switch and blocks are used to control the position of the gate.
- Release the gear with the key and push the sliding gate manually to pre-determine the position, fix the block to the rack and lock the gear by push up the release bar. Moving the gate electrically, adjust the block to the proper position until the position of the opening and closing meet the requirement.

Magnetic limit switch

- To ensure safety, it is recommended to install limit switches at both ends of the gate to prevent the gate from sliding out of the rails. The rails must be installed horizontally.
- Install the limit block as shown in Fig.5 and Fig.6. The magnetic of limit switch and blocks are used to control the position of the gate.
- Release the gear with the key and push the sliding gate manually to pre-determine the position, fix the block to the rack and lock the gear by push up the release bar. Moving the gate electrically, adjust the block to the proper position until the position of the opening and closing meet the requirement.

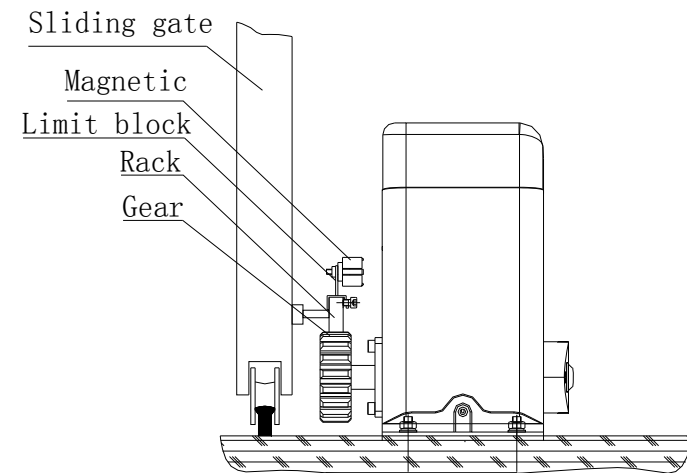
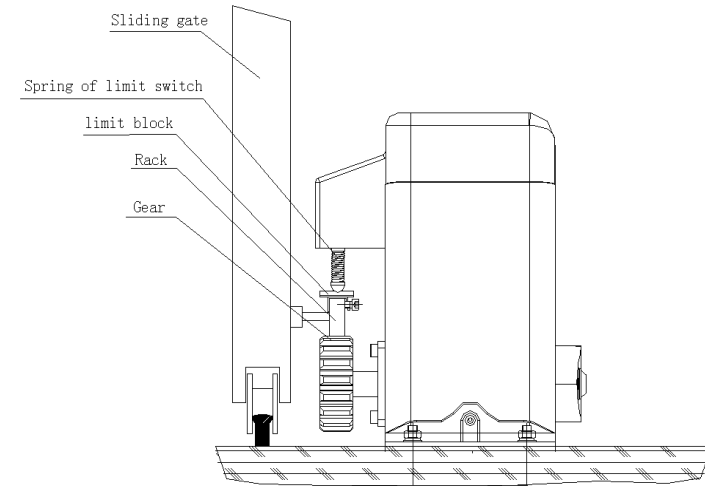

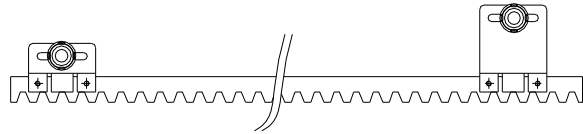

Fig.5

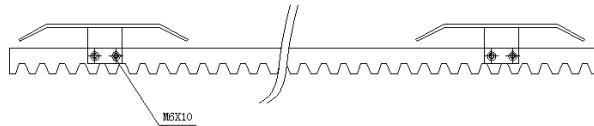

Fig.6

Manual operation

In case of power failure use key unlock the lock and pull down the release bar about 90 degree to open or close gate manually, use the release key as follow:

- Fit the supplied key in the lock.
- Turn the key and pull down the release bar about 90° to release the gear. (Note: Do not exceed 90°, be careful not to use too much force, otherwise the release bar will be damaged.)
- Open and close the gate manually.

Note: If the gate bumps the mounting post and cannot be electric opened, move the gate a few inches by hand, thus you can release the gate with the key, open and close the gate manually.

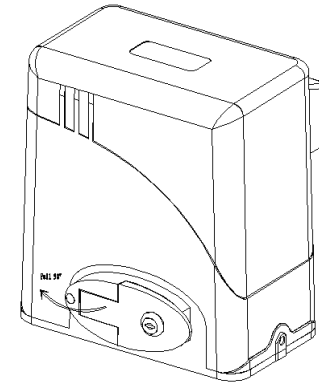

Fig.7

6. Wire Connecting

Make sure that the power is OFF before making any electrical connections.

Remove the cover, perform the wiring (See Fig.8 and wiring notes for control board) and replace the cover again.

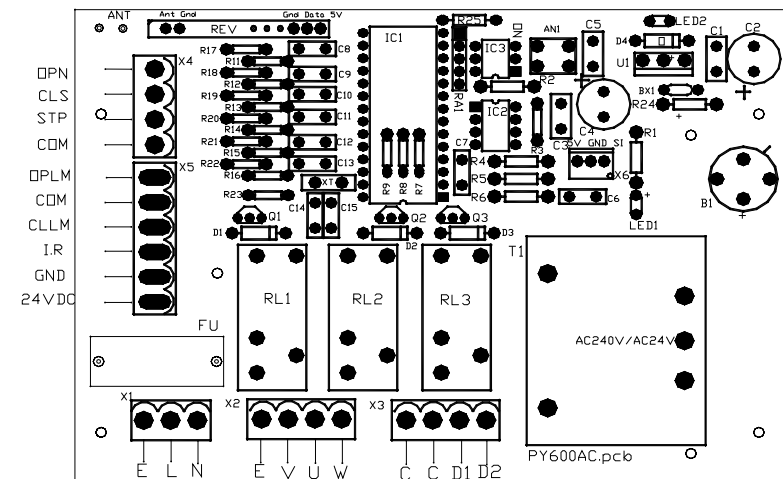

Fig.8

Wiring notes of control board

- a. Power Input(X1):E (Earth),L (Live),N (Neutral).
 PY600AC: AC220V
 PY600ACU:AC110V
- b. Caution light: connect caution light wire toD1 and D2(terminal X3)
 PY600AC: AC220V
 PY600ACU : AC110V
- c. Output power supply: 24VDC, COM (COM), I.R. (N.C Infrared)
 If the infrared beam is interrupted during closing, the gate will reverse and open immediately. The product is not factory equipped with an infrared device, the infrared output signal must be N.C.

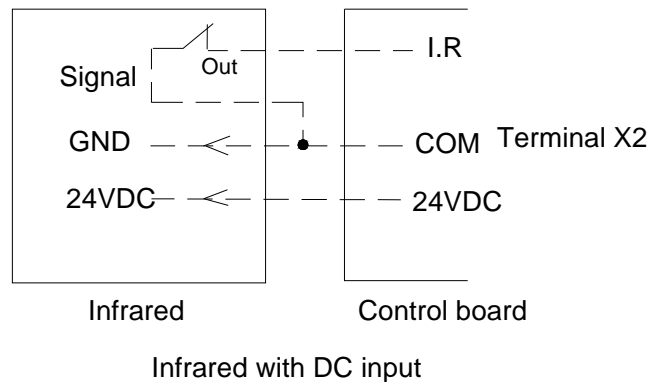

Fig.9 infrared Schematic diagram

- d. Three-button switch / single-button switch (keypad): The PY600AC is equipped with interfaces for three-button switch and single-button switch (keypad).
 To install the keypad attach one lead of your keypad to 'CLS' of terminal X4 and the other to the 'COM'. The keypad will function in single channel mode (the DIP switch 1 should be turn to OFF). For three-button switch installation, use the terminals for

multi-channel mode. Connect open wire of external button switch to 'OPN' of terminal X4, connect close wire of switch to 'CLS', connect stop wire of switch to 'STP', connect common wire of switch to 'COM'.

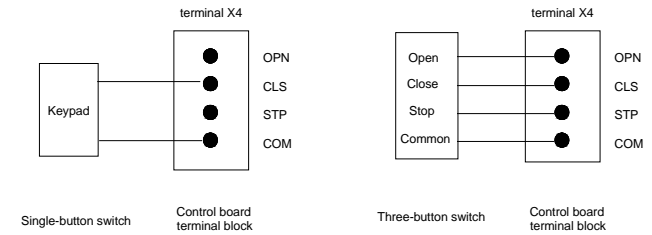

Fig.10

Motor and capacitor (Terminal X2, X3): V (com), U (Positive direction), W (Opposite direction), E (grounding), C (capacitor)

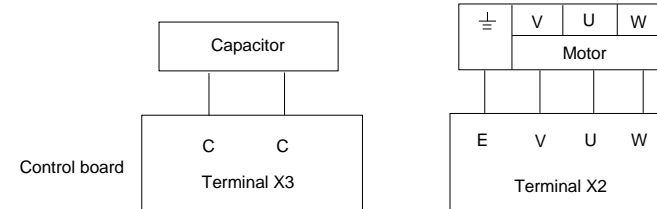

Fig.11

7. Tuning and operation

Remote control

- The remote control works in a single channel mode. It has four buttons. See Fig.12 Remote transmitter. The function of button 1, button 2, button3 and button 4 are the same. With each press

of the remote control button which has been programmed, the gate will close, stop, open or stop cycle.

- You can program/learn button 1, button 2, button 3 individually. You also can program/learn two buttons or three buttons together, but you need repeat the program/learn process if you want to use more than one button.

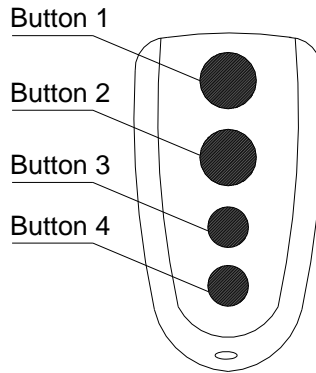

Fig.12 Remote transmitter

- Adding extra remote controls (Learn):** Remove the cover, press the learn button 'AN1' (Fig.8), then the 'LED2' (Fig.8) will be on and turn off, then press the remote control button which you want to use, the 'LED2' will turn on about 2 seconds and then turn off again. The learning process is finished. Up to 25 remote controls may be used.
- Erase remote controls:** To erase all existing remote controls, press and hold learn button 'AN1', the 'LED2' turns on, release the button once the 'LED2' turns off. This indicates that all the remote controls have been erased completely.
- Note:** Press the 'OPEN' button of external button switch or remote control button which has been learned, the gate will open, the motor rotates clockwise, and the 'LED2' is turns on. The output voltage between 'D1 and D2' (terminal X3) is

AC220V/110V, the voltage between 'V' and 'U' is AC220V/110V. Press 'STOP' button or the same remote control button, the gate stops running. And the 'LED2' is turns off. Then press 'CLOSE' button or the same remote control button again, the gate will close, the motor rotates anticlockwise, and the 'LED2' is turns on. The output voltage between 'D1 and D2' (terminal X3) is AC220V/110V, the voltage between 'V' and 'W' is AC220V/110V. Press the 'STOP' button or the same remote control button, the gate stops running. And the 'LED2' is turns off.

- Verify open direction:** If the gate does not move in the desired direction, then you will need to reverse the motor operating direction, open the black plastic cover, you can do this by exchanging wires 'U' and 'W', 'OPLT' and 'CLLT'.

8. Programming Process

Table of the DIP-switch

Position	DIP-switch	Function SET
1	ON	Three-button switch
	OFF	Single-button switch (the CLS and COM), OPN and COM is "open door" function also.
2	ON	When the 2 and 3 all ON, the Controller haven't Auto-close function. When the 2 ON and the 3 is OFF, auto-close time is near 20 Sec. when the 2 OFF and the 3 is ON auto-close time is near 40 sec. when the 2 and the 3 is all in position, the auto-close time is near 60 sec.
	OFF	
3	ON	
	OFF	

Note:

- (1) **You must follow the operating instruction as above, any wrong operation is not allowed during setting. If your device responds to your requested function correctly, you have set the function successfully, otherwise repeat the above setup instruction until your device responds to your expected function.**
- (2) **If the gate can not be moved, please check whether the gate is obstructed or the gate is too weight.**

Activities Covered in this section

- **Remote transmitter:** With each press of the button, the gate will close, stop, open or stop cycle. **(Single-button mode)**
- **Three-button mode external button switch (not supply):** press 'OPEN' button, the gate opens. Press 'STOP' button, the gate stops. Press 'CLOSE' button, the gate closes.
- **Single-button mode external button switch / keypad (not supply):** With each press of the button, the gate will close, stop, open or stop cycle.
- **Auto-close function:** This feature can be selected to make the gate stay open for some seconds before it automatically closes. The auto-close time can be adjusted to between 15, 30 and 45 seconds.
- **Safe guard (Infrared photocell):** If infrared beam is interrupted during closing, the gate will reverse and go open immediately. This feature will not function if the gate is in fully opened and closed positions or during opening.
- **Open priority:** The gate will return to open if press 'OPEN' button of external button switch during closing.
- **Limit switch:** The switch is used to accurately stop the gate in the opened and closed positions.
If the gate stops at opened position when the limit switch is

reached, the gate will not move if you press 'OPEN' button.

If the gate stops at closed position when the limit switch is reached, the gate will not move if you press 'CLOSE' button.

- The device is installed with a thermal protector, the thermal protector will switch off the motor automatically in case of the temperature is higher than 120°C and switch on the motor automatically when the temperature is lower than 85°C ± 5 °C.

9. Maintenance

- Check the door once a month. The door should be carefully checked for balance. The door must be in good working order.
- We suggest for safety reasons, photocells be used on all gates.
- Disconnect from mains supply before replacing bulb.
- Be sure to read the entire manual before attempting to perform any installation or service to the door operator.
- Our company reserves the right to change the design and specification without prior notification.

10. Troubleshooting

Trouble	Possible causes	Solutions
The door fails to open and close. LED display does not light.	1. Power is OFF 2. Fuse burn	1. Make sure that power is ON. 2. Replace fuse.
The door can open, fails to close.	1. Infrared beam is obstructed. 2. Infrared photocell function is enable, but the photocell has not been installed.	1. Remove obstructions. 2. Make sure the infrared photocell function is disable.

Remote transmitter does not work.	1. Battery level may be low 2. Transmitter code is lost	1. Replace the battery inside the transmitter. 2.Re-program the transmitter.
The transmitter operating distance is too short.	Battery level may be low.	Replace battery.

11. Packing list

After receiving the gate operator, you should make an unpack-inspection, in which you should check whether the product was damaged. If you have any problem please contact our dealer. You should find the following items in our standard packing:

No.	Item	Quantity
1	PY600AC sliding gate operator	1
2	Transmitter	2
3	Release key	2
4	User's manual	1

OUTLINE

1. Products introduction1

2. Important safety precautions1

3. Main technical parameters 1

4. Mechanical Installation2

5. Adjustment 6

6. Wire Connecting 9

7. Turning and operation 11

8. Programming Process13

9. Maintenance15

10. Trouble Shooting.....15

11. Packing list16